

• 15P0068B1 •

CLAMPING UNIT CU400

USER MANUAL -Installation Instructions-

Upd. 22/03/18
R 02

English

- This manual is integrant and essential to the product. Carefully read the instructions contained herein as they provide important hints for use and maintenance safety.
- This device is to be used only for the purposes it has been designed to. Other uses should be considered improper and dangerous. The manufacturer is not responsible for possible damages caused by improper, erroneous and irrational uses.
- Elettronica Santerno is responsible for the device in its original setting.
- Any changes to the structure or operating cycle of the device must be performed or authorized by the Engineering Department of Elettronica Santerno.
- Elettronica Santerno assumes no responsibility for the consequences resulting by the use of non original spare-parts.
- Elettronica Santerno reserves the right to make any technical changes to this manual and to the device without prior notice. If printing errors or similar are detected, the corrections will be included in the new releases of the manual.
- Elettronica Santerno is responsible for the information contained in the original version of the Italian manual.
- The information contained herein is the property of Elettronica Santerno and cannot be reproduced. Elettronica Santerno enforces its rights on the drawings and catalogues according to the law.



Elettronica Santerno S.p.A.
Via della Concia, 7 - 40023 Castel Guelfo (BO) Italia
Tel. +39 0542 489711 - Fax +39 0542 489722
santerno.com info@santerno.com

0. TABLE OF CONTENTS

0. TABLE OF CONTENTS	2
1. GENERAL FEATURES	3
2. CAUTION STATEMENTS	4
3. INSPECTION UPON RECEIPT OF THE GOODS	5
4. EQUIPMENT DESCRIPTION AND INSTALLATION.....	5
4.1. General Features	5
4.1.1. Application Table	7
4.1.2. Nameplate.....	7
4.2. Installation.....	8
4.2.1. Environmental Requirements for the Equipment Installation, Storage and Transport	8
4.2.2. Cooling System and Dissipated Power	9
4.2.3. Dimensions and Weight.....	9
4.2.4. Standard Mounting.....	10
4.3. Wiring	11
4.3.1. Connecting CU400 to DCREG	11
4.3.2. Power Terminals Arrangement	12
4.3.3. Cross-sections of Power Connection Cables and Protections.....	13
5. SPECIFICATIONS.....	13

1. GENERAL FEATURES

**NOTE**

The structure and the technical features of the clamping unit model can be changed without prior notice and are not binding to the end user.

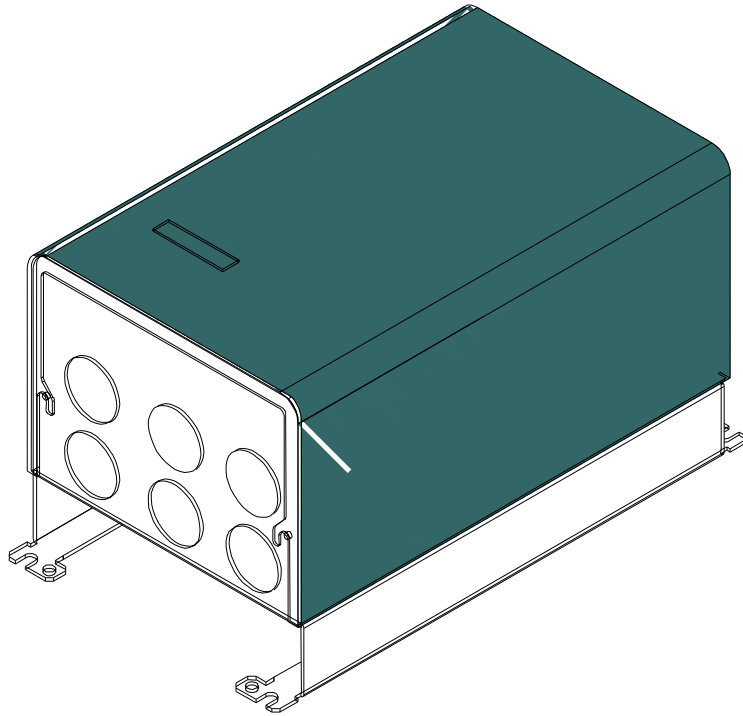

2. CAUTION STATEMENTS

This section contains safety statements. The non-observance of these safety instructions may cause serious injury or death and equipment failure. Carefully read the instructions below before installing, starting and operating the equipment.

Only competent personnel must carry out the equipment installation.

SYMBOLS:



DANGER

Indicates operating procedures that, if not correctly performed, may cause serious injury or death due to electrical shock.



CAUTION

Indicates operating procedures that, if not carried out, may cause serious equipment failure.



NOTE

Indicates important hints concerning the equipment operation.

SAFETY STATEMENTS TO FOLLOW WHEN INSTALLING AND OPERATING THE EQUIPMENT:



NOTE

Always read this instruction manual before starting the equipment.



DANGER

ELECTRICAL SHOCK HAZARD – Never touch the electrical parts when the equipment is on; always wait at least 5 minutes after switching off the equipment.



DANGER

Never perform any operation on the magnet when the DCREG is on.



DANGER

Do not perform electrical connections when the converter is on. Electrical shock hazard exists on output terminals (B1, B2) even when the converter is disabled. Wait at least 5 minutes after switching off the converter before operating on the electrical connection of clamping unit CU400.



DANGER

EXPLOSION AND FIRE – Explosion and fire hazard exists if the equipment is installed in presence of flammable fumes. Do not install the equipment in places exposed to explosion and fire hazard, even if the magnet is installed there.



CAUTION

Do not connect supply voltages exceeding the equipment rated voltage to avoid damaging the internal circuits.



CAUTION

Do not connect the equipment power supply to the output terminals (B1, B2) or the control terminals. The equipment power supply must be connected only to the relevant terminals.



CAUTION

Do not perform any isolation test between the power terminals or the control terminals.



CAUTION

Make sure that the fastening screws of the control terminal board and the power terminal board are properly tightened.



CAUTION

Respect the environmental requirements for the equipment installation.

3. INSPECTION UPON RECEIPT OF THE GOODS

Make sure that the equipment is not damaged and it complies with the equipment you ordered by referring to the nameplate located on the clamping unit front part. The CU nameplate is described below. If the equipment is damaged, contact the supplier or the insurance company concerned. If the equipment does not comply with the one you ordered, please contact the supplier as soon as possible.

If the equipment is stored before being started, make sure that the ambient conditions do not exceed the ratings mentioned in section "Installation". The equipment guarantee covers any manufacturing defect. The manufacturer has no responsibility for possible damages due to transportation or unpacking. The manufacturer is not responsible for possible damages or faults caused by improper and irrational uses; wrong installation; improper conditions of temperature, humidity, or the use of corrosive substances. The manufacturer is not responsible for possible faults due to the equipment operation at values exceeding the equipment ratings and is not responsible for consequential and accidental damages. The equipment is covered by a 3-year guarantee starting from the date of delivery.

Product ID:

CU 400

CU = ID code

400 = rated voltage

4. EQUIPMENT DESCRIPTION AND INSTALLATION

4.1. General Features

Clamping unit CU400 protects a DC converter when it is subject to dangerous overvoltage conditions generated when the current conduction mesh of the magnet unexpectedly opens. Power is cut by CU400, which avoids dangerous overvoltage conditions. Overvoltage depends on the time when power is cut:

$$V = L \frac{dI}{dt}$$

Energy stored in the magnet, calculated with the formula below,

$$E = \frac{1}{2} LI^2$$

is "absorbed" and stored in an RC-type clamping circuit, where overvoltage is limited by a capacitor and is dissipated by resistor R.

To ensure proper clamping, unit CU400 must be connected directly to the converter DC side. To suppress the first current peak generated by the capacitor, this is precharged when connecting the main voltage of the mains (typically 400 VAC) to the relevant terminals in terminal board X1.

Figure 1 illustrates the system operation:

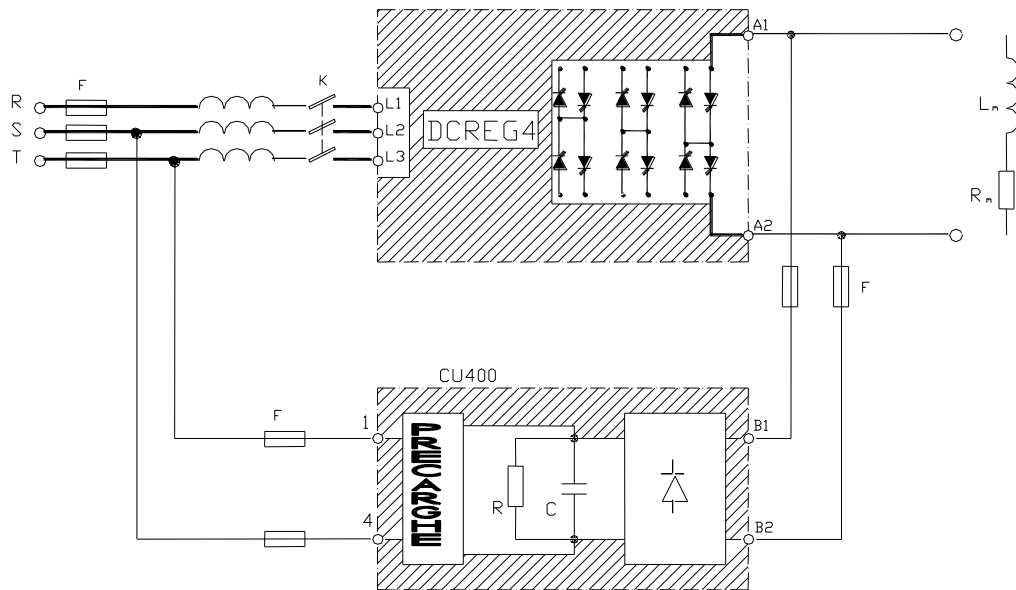





Figure 1: System operation

4.1.1. APPLICATION TABLE

DCREG Size	Clamping Unit	External Capacitor (microF)	Max. inductance of the Magnet	Mains Max. Voltage (VAC)
DCREG4. 10	CU400	None	1 Henry	440
DCREG4. 20	CU400	None	1 Henry	440
DCREG4. 40	CU400	None	1 Henry	440
DCREG4. 70	CU400	None	1 Henry	440
DCREG4.100	CU400	None	1 Henry	440
DCREG4.150	CU400	None	0.8 Henry	440
DCREG4.180	CU400	2x 3300	0.8 Henry	440
DCREG4.250	CU400	2x 6800	0.6 Henry	440
DCREG4.350	2x CU400	None	0.6 Henry	440
DCREG4.410	3x CU400	None	0.5 Henry	440

4.1.2. NAMEPLATE

Example of a nameplate applied to the clamping unit:

ZZ0068040		Clamping Unit CU400	
Size S0	Voltage	Frequency	Current
INPUT	AC 3PH 220 ..440 V +10/-15%	50/60 Hz ±20%	
OUTPUT			Inom 130 A Imax 150 A
Applicable Magnet Power (kW)			
	Voltage	Frequency	Current
	AC 3PH 220 ..440 V		130 A
Protection degree IP00			
FOR FURTHER DETAILS SEE USER MANUAL		 	
Elettronica Santerno S.p.A Via della Concia n° 7 40023 Castel Guelfo (BO) - Italy santerno.com MADE IN ITALY		STANDARD Immunity: EN 500082-1-2 EN 61800-3 Ed. 2 Emission: EN 550011 gr. 2 cl. A Safety: EN 61800-5-1 EN 50178 EN 60204-1 IEC 22/G/109/NP	

S001017

4.2. Installation



CAUTION The clamping unit must be connected directly to the output terminals of the DCREG.



CAUTION The bottom of the clamping unit may reach high temperatures; make sure that the bearing surface is not heat-sensitive.

4.2.1. ENVIRONMENTAL REQUIREMENTS FOR THE EQUIPMENT INSTALLATION, STORAGE AND TRANSPORT

Operating ambient temperatures	0-40°C with no derating from 40°C to 50°C with a 2% derating of the rated current for each degree beyond 40°C
Ambient temperatures for storage and transport	- 25°C - +70°C
Installation environment	Pollution degree 2 or higher. Do not install in direct sunlight and in places exposed to conductive dust, corrosive gases, vibrations, water sprinkling or dripping; do not install in salty environments.
Altitude	Up to 1000 m above sea level. For higher altitudes, derate output current of 2% every 100m above 1000m (max. 4000m).
Operating ambient humidity	From 5% to 95%, from 1g/m ³ to 25g/m ³ , non condensing and non freezing (class 3k3 according to EN50178)
Storage ambient humidity	From 5% to 95%, from 1g/m ³ to 25g/m ³ , non condensing and non freezing (class 1k3 according to EN50178).
Ambient humidity during transport	Max. 95%, up to 60g/m ³ ; condensation may appear when the equipment is not running (class 2k3 according to EN50178)
Storage and operating atmospheric pressure	From 86 to 106 kPa (classes 3k3 and 1k4 according to EN50178)
Atmospheric pressure during transport	From 70 to 106 kPa (class 2k3 according to EN50178)



CAUTION Ambient conditions strongly affect the equipment life. Do not install the equipment in places that do not have the above-mentioned ambient conditions.

4.2.2. COOLING SYSTEM AND DISSIPATED POWER

No heat is generated by the clamping unit, except during the short time when energy is dissipated from the magnet. Because this seldom occurs, the mean dissipated power is very weak and never exceeds 20 Watts. When the clamping unit is supposed to be installed in a mains subject to strong disturbance or to frequent power cuts, instant power dissipated by CU400 is equal to approx. 1.5 kW. The mean power to be considered for the cooling of CU400 is given by the formula:

$$P_m = 20 * N \text{ (watts)}$$

where N = number of estimated power cuts per hour

4.2.3. DIMENSIONS AND WEIGHT

Overall dimensions of CU400 are the following:

Height	H = 348 mm
Width	W = 130 mm
Depth	D = 130 mm
Weight	3.9 kg

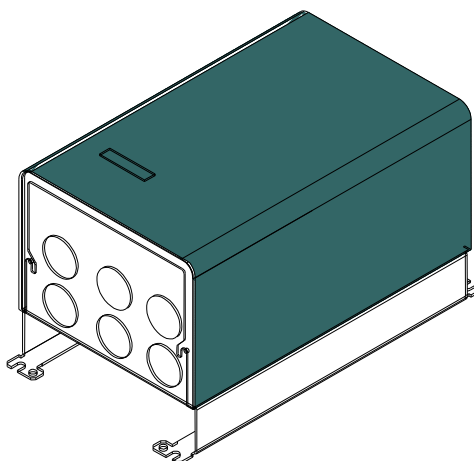

4.2.4. STANDARD MOUNTING

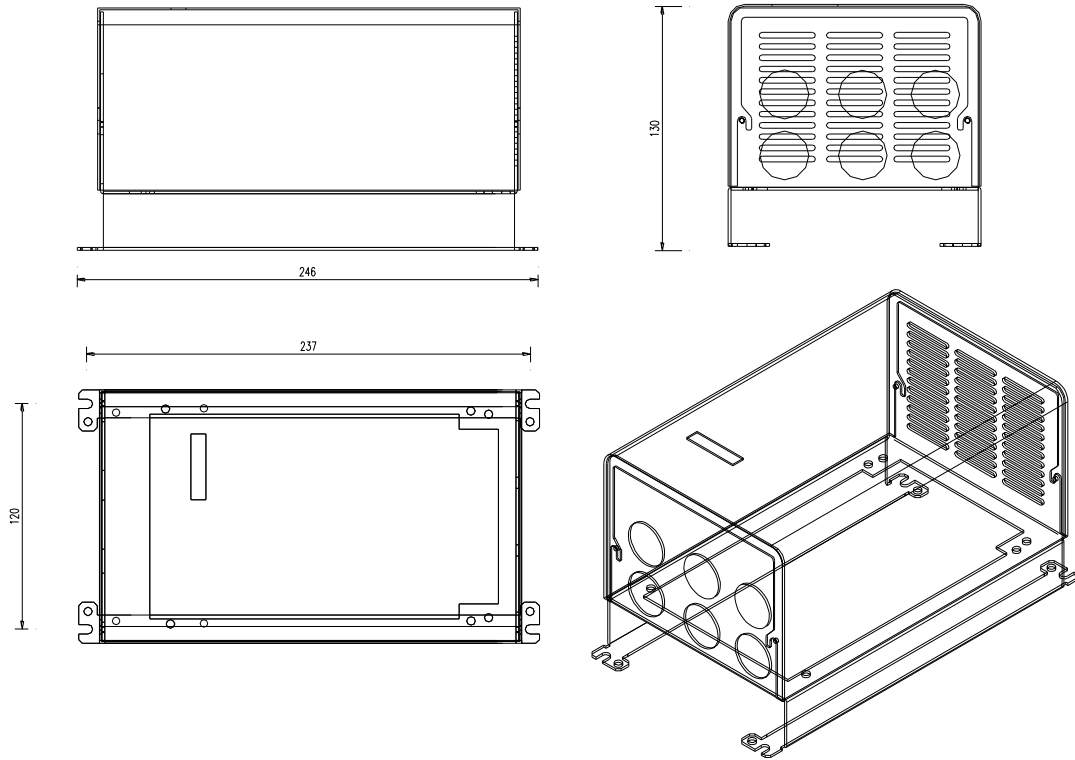

4.3. Wiring

4.3.1. CONNECTING CU400 TO DCREG

Clamping unit CU400 must be connected to an AC/DC converter used to power the magnets. Four electrical connections are needed: two connections on the converter DC side, two connections to the main mains. Due to these connections, the internal components of the clamping unit are exposed to the mains potential. Connections are illustrated in Figure 2.

If magnets with current ratings exceeding 150 A are required (see Table 4.3.3), multiple parallel-connected clamping units can be used.

For applications exceeding 150 A, additional capacitors are required, or multiple clamping units must be parallel-connected.

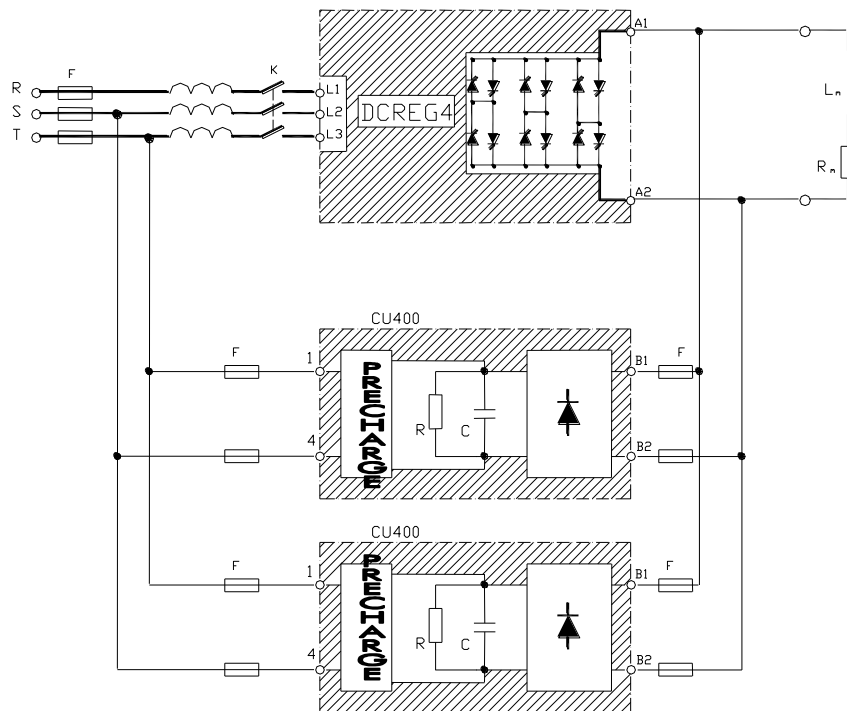

Figure 2: Parallel-connected CU400 Units

4.3.2. POWER TERMINALS ARRANGEMENT

To gain access to the power terminals, just remove the cover of the clamping unit. To do so, loosen the four fastening screws of the cover, located both on the front side and on the rear side.

Just loosen the fastening screws to remove the cover from the top.

Power terminals B1 and B2 are made of two copper bars, that can be reached from the two front holes in the bottom right corner of the CU base.

Terminal board M1 (used for precharge mains voltage) can be reached from the front hole in the top left corner (see fig. below); this connection is protected against internal short-circuits.

The terminals to be connected to external capacitors (if any) are called (+) and (-); always check the terminal polarity before connecting any capacitor.

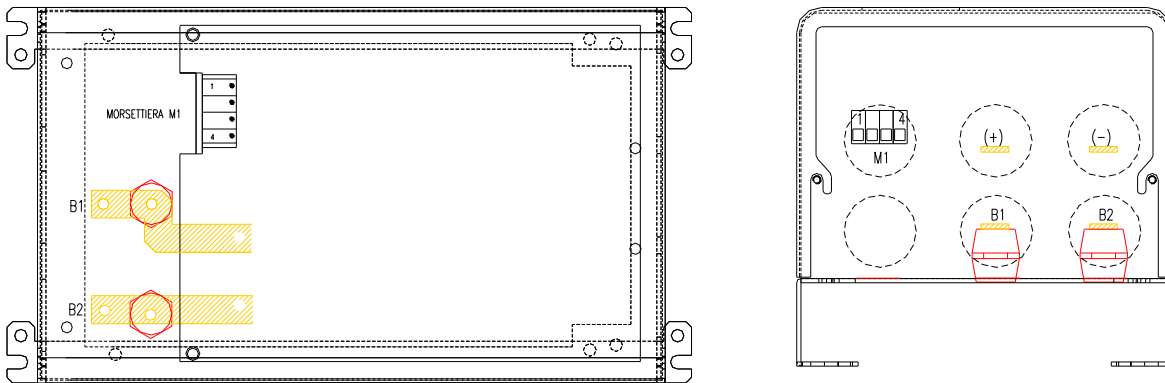

B1	Connection to copper bar – Connection to the DC-side of the DCREG
B2	Connection to copper bar – Connection to the DC-side of the DCREG
(+)	Connection to copper bar – Connection of external capacitors
(-)	Connection to copper bar – Connection of external capacitors
M1 1	mains voltage connection (400 VAC – 50 Hz)
M1 4	mains voltage connection (400 VAC – 50 Hz)



DANGER

Before changing the equipment connections, shut off the inverter and wait at least 5 minutes to allow for the discharge of the heatsinks in the DC-link.



CAUTION

Always make sure that the supply voltage ranges between the limits stated in the inverter nameplate.



CAUTION

Always connect the ground terminal to avoid electrical shock hazard and to limit disturbance.

The user has the responsibility to provide a grounding system in compliance with the regulations in force.



CAUTION

After connecting the equipment, check the following:

- all wires must be properly connected;
- no link is missing.

4.3.3. CROSS-SECTIONS OF POWER CONNECTION CABLES AND PROTECTIONS

Converter size amperes	Camping unit	Terminals CU 400	Cross section sqmm	Fuse size amperes	Terminals CU 400	Cross section sqmm	Terminals CU 400	Cross section sqmm
20	CU 400	B1 - B2	6	50	(+) e (-)	6	M1:1 ed M1:2	1,5
40	CU 400	B1 - B2	10	50	(+) e (-)	6	M1:1 ed M1:2	1,5
70	CU 400	B1 - B2	10	50	(+) e (-)	6	M1:1 ed M1:2	1,5
100	CU 400	B1 - B2	16	50	(+) e (-)	6	M1:1 ed M1:2	1,5
150	CU 400	B1 - B2	16	50	(+) e (-)	10	M1:1 ed M1:2	1,5
>150	CU 400	B1 - B2	16	50	(+) e (-)	16	M1:1 ed M1:2	1,5

A delayed fuse (gL-type) is needed to protect power-side connections of terminals B1 and B2.
 No fuse is required to protect the connections of the external capacitors (if any). The two internal capacitors must be series-connected; the voltage balancing resistance is included in the capacitor mounting kit.
 You can use 1.5 sqmm cables to connect precharge terminals M1: 1 and M1:4. The clamping unit is protected against internal short-circuits; however, a delayed fuse (1A) is required to protect cables against external short-circuits.

Wiring Diagram for External Capacitors

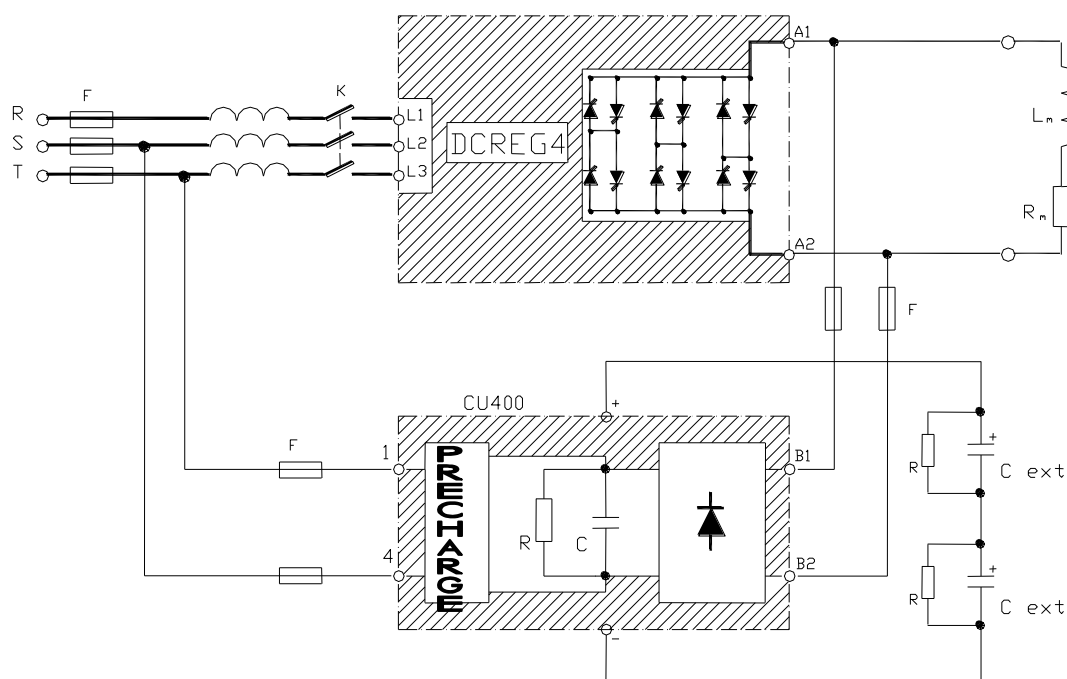

Figure 3: Capacitor Connections

5. SPECIFICATIONS

Maximum supply voltage for DCREG converter	440 VAC
Maximum current of the magnet	150 A
Maximum power to be dissipated in 5 s	5,000 J
Mean power to be dissipated	200 W